

EVB SERIES

An excellent choice for applications requiring high positional accuracy and dynamic performance. The EVB is a ≤ 4 arc-min gearbox that offers a right angle design with a through hole mounting style, making it compact and easy to assemble onto various equipment. This product is an ideal fit for various belt drive and actuator applications found throughout the packaging and assembly cell automation markets.

Various standard wash down and food grade options are available, making the EVB an attractive choice for the toughest environments. We offer the broadest selection of frame sizes and ratios, with immediate availability on most configurations. Industry standard mounting dimensions allow the EVB to be employed in legacy equipment designs, saving our customers time and money.

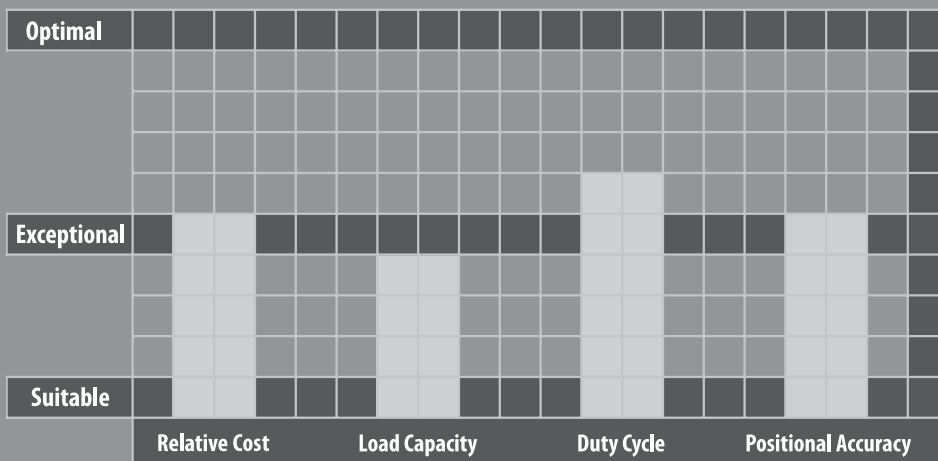

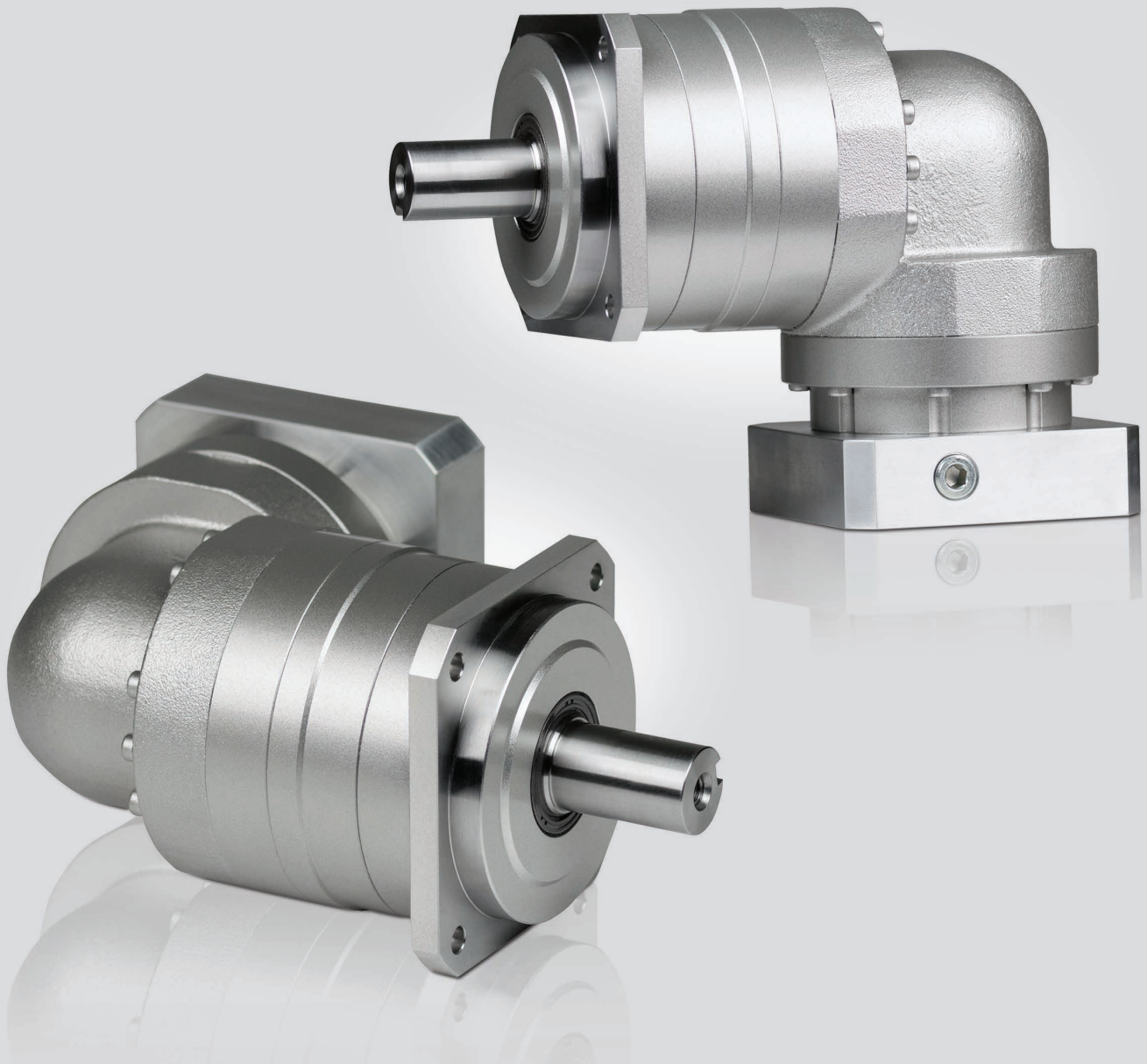

EVB SERIES

- Compact, space-saving solution for mid to high end motion control applications
- The widest range of frame sizes and ratios available in the market
- Best-In-class backlash (≤ 4 arc-min)
- Broad range of mounting adapters offer a simple, precise attachment to any motor
- Maintenance-free solution that is lubricated for life. High performance grease allows flexible mounting in any orientation
- Industry standard mounting dimensions
- Assembled in the USA

EVB SERIES Right-angle Planetary

EVB Series Features

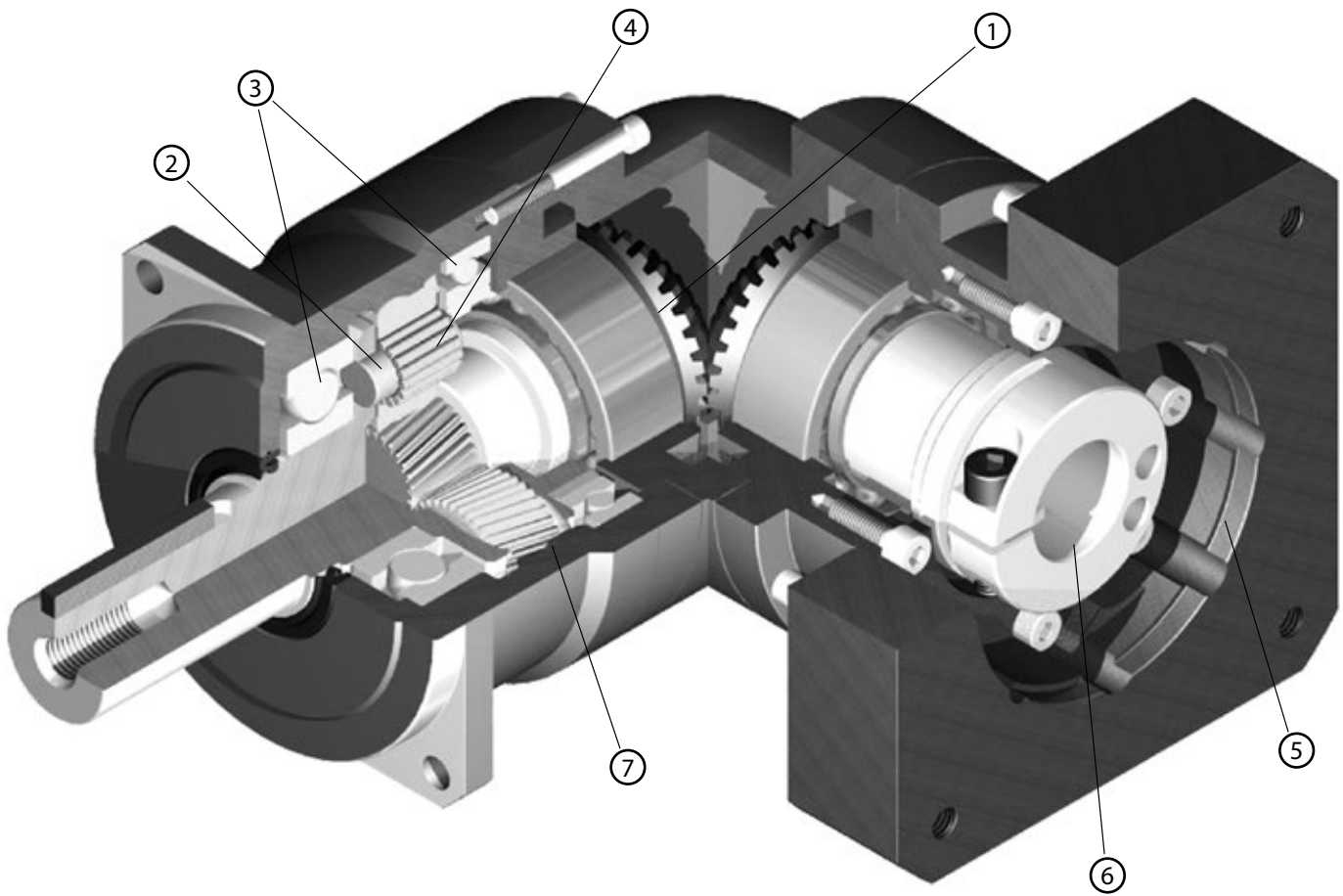

- ① Right angle bevel gear configuration allows motor to be mounted at a 90 degree position from the gearbox, saving space
- ② Carburized helical gears with proprietary secondary finishing process for higher accuracy and smooth, quiet operation. 40% higher tooth surface area than the industry standard
- ③ One piece output shaft and planet carrier with two bearings straddling the planet gears. Higher stiffness, torque capacity and safety factor, with guaranteed alignment of gearing
- ④ Uncaged needle roller bearings provide excellent torque density and torsional rigidity. 43% larger bearing surface area compared to the rest of the industry
- ⑤ Optimized mounting system with active centering on motor pilot diameter guarantees alignment of motor. Motor can be installed in any orientation
- ⑥ True concentric motor shaft clamping connection, optimized for your specific motor. Reduced inertia for dynamic performance and balanced for high speed operation
- ⑦ Ring gear machined directly into the housing, not welded or pressed in. Provides greater concentricity and elimination of speed fluctuation

EVB Series Model Code

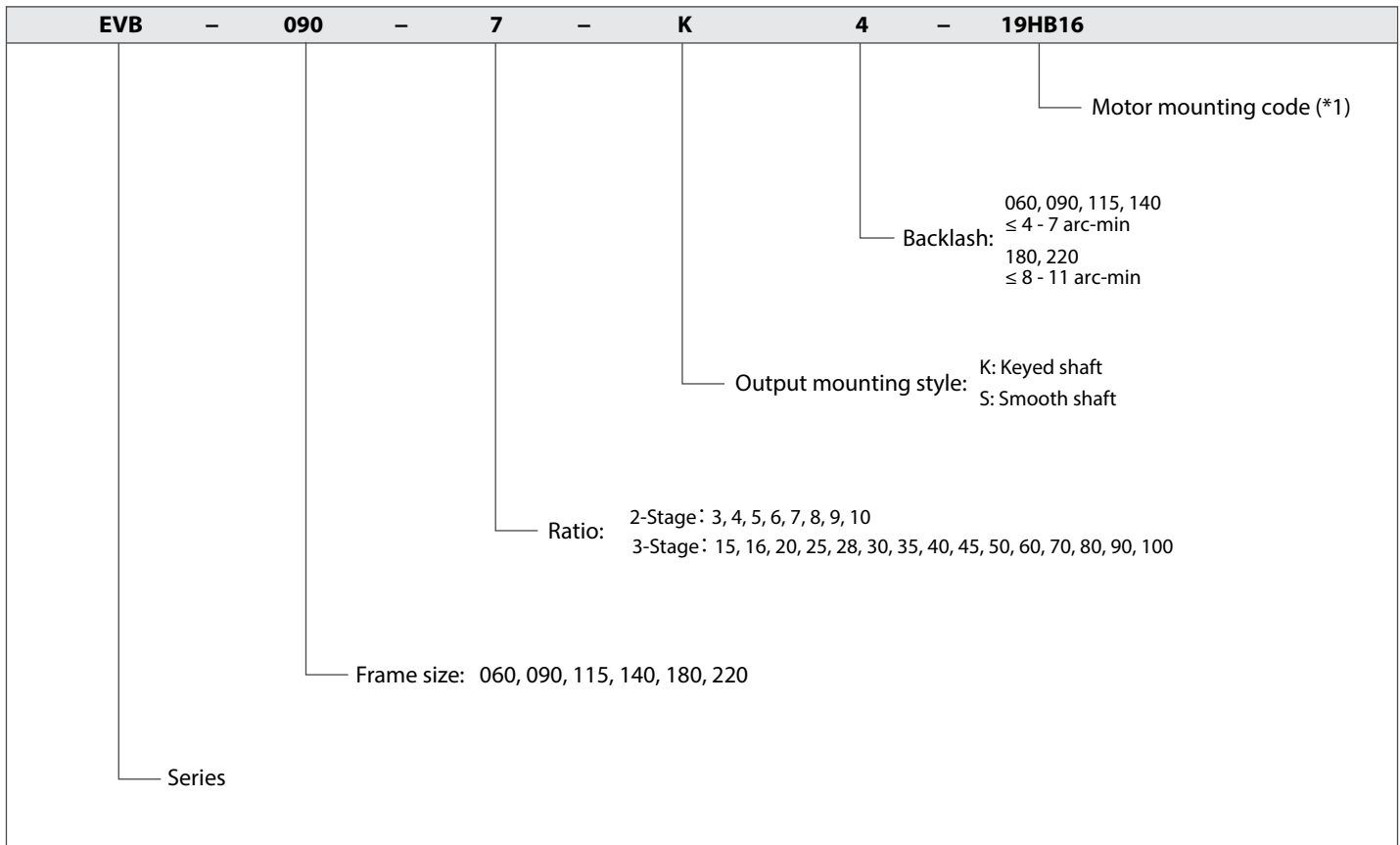

EVB

*1) Motor mounting code varies depending on the motor. Use the selection tool link below to configure the code.

Contact us for additional information or refer to our online gearbox selection tool.
 Selection tool www.nidec-shimpo.co.jp/selection/eng

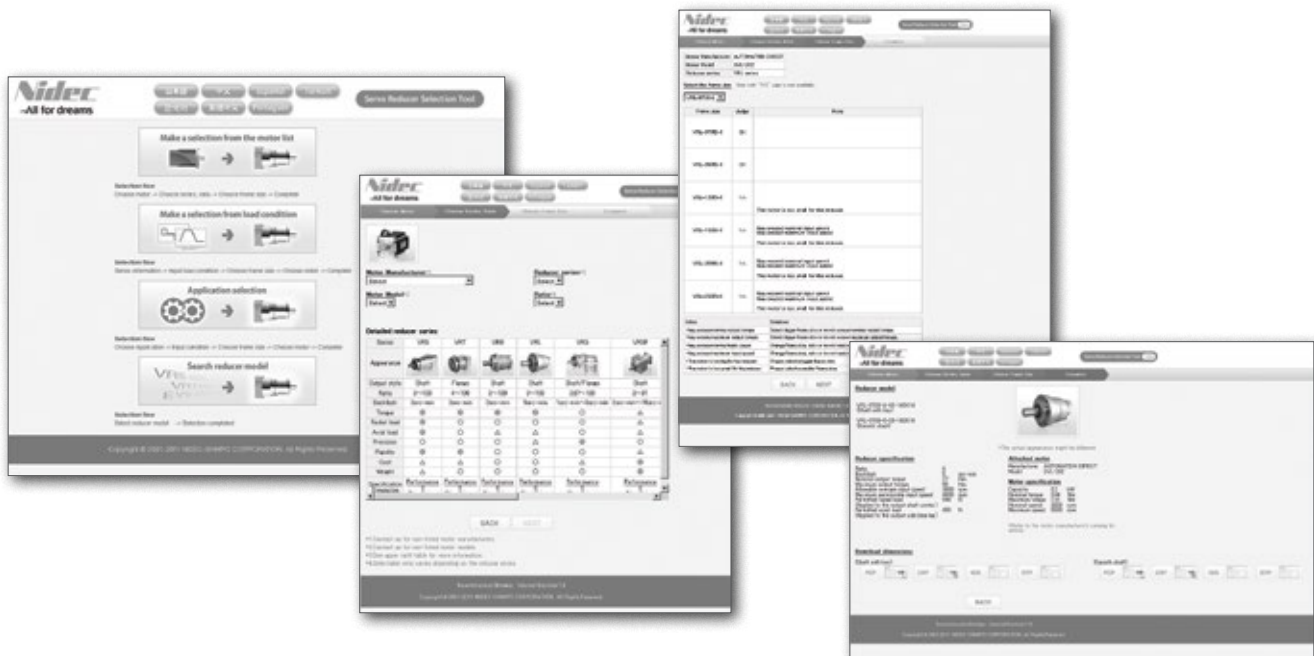

EVB SERIES Right-angle Planetary

EVB o6o 2-Stage Specifications

Frame Size	060									
Ratio	Unit	Note	3	4	5	6	7	8	9	10
Nominal Output Torque	[Nm]	*1	12	16	22	24	24	24	16	16
Maximum Acceleration Torque	[Nm]	*2	24	32	40	45	45	45	32	32
Emergency Stop Torque	[Nm]	*3	50	65	80	90	90	90	65	65
Nominal Input Speed	[rpm]	*4	3000							
Maximum Input Speed	[rpm]	*5	6000							
No Load Running Torque	[Nm]	*6	0.33							
Permitted Radial Load	[N]	*7	430	470	510	540	570	600	620	640
Permitted Axial Load	[N]	*8	310	360	390	430	460	480	510	530
Maximum Radial Load	[N]	*9	1200							
Maximum Axial Load	[N]	*10	1100							
Moment of Inertia ($\leq \varnothing 8$)	[kgcm ²]	--	0.310	0.270	0.250	0.240	0.230	0.230	0.230	0.230
Moment of Inertia ($\leq \varnothing 14$)	[kgcm ²]	--	0.390	0.340	0.320	0.310	0.310	0.310	0.300	0.300
Moment of Inertia ($\leq \varnothing 19$)	[kgcm ²]	--	0.580	0.530	0.510	0.500	0.500	0.500	0.490	0.490
Efficiency	[%]	*11	93							
Torsional Rigidity	[Nm/arc-min]	*12	3							
Maximum Torsional Backlash	[arc-min]	--	≤ 4							
Noise Level	dB [A]	*13	≤ 80							
Protection Class	--	*14	IP54 (IP65)							
Ambient Temperature	[°C]	--	0-40							
Permitted Housing Temperature	[°C]	--	90							
Weight	[kg]	*15	1.8							

EVB o6o 3-Stage Specifications

Frame Size	060									
Ratio	Unit	Note	15	16	20	25	28	30	35	40
Nominal Output Torque	[Nm]	*1	16	24	24	24	24	16	24	24
Maximum Acceleration Torque	[Nm]	*2	32	45	45	45	45	32	45	45
Emergency Stop Torque	[Nm]	*3	65	90	90	90	90	65	90	90
Nominal Input Speed	[rpm]	*4	3000							
Maximum Input Speed	[rpm]	*5	6000							
No Load Running Torque	[Nm]	*6	0.20							
Permitted Radial Load	[N]	*7	740	750	810	870	910	930	980	1000
Permitted Axial Load	[N]	*8	630	650	720	790	830	860	920	970
Maximum Radial Load	[N]	*9	1200							
Maximum Axial Load	[N]	*10	1100							
Moment of Inertia ($\leq \varnothing 8$)	[kgcm ²]	--	0.073	0.079	0.071	0.071	0.077	0.062	0.070	0.061
Moment of Inertia ($\leq \varnothing 14$)	[kgcm ²]	--	0.118	0.124	0.116	0.115	0.122	0.106	0.115	0.106
Efficiency	[%]	*11	88							
Torsional Rigidity	[Nm/arc-min]	*12	3							
Maximum Torsional Backlash	[arc-min]	--	≤ 7							
Noise Level	dB [A]	*13	≤ 80							
Protection Class	--	*14	IP54 (IP65)							
Ambient Temperature	[°C]	--	0-40							
Permitted Housing Temperature	[°C]	--	90							
Weight	[kg]	*15	1.6							

EVB 060 3-Stage Specifications

Frame Size	060										
Ratio	Unit	Note	45	50	60	70	80	90	100		
Nominal Output Torque	[Nm]	*1	16	24	24	24	24	16	16		
Maximum Acceleration Torque	[Nm]	*2	32	45	45	45	45	32	32		
Emergency Stop Torque	[Nm]	*3	65	90	90	90	90	65	65		
Nominal Input Speed	[rpm]	*4	3000								
Maximum Input Speed	[rpm]	*5	6000								
No Load Running Torque	[Nm]	*6	0.20								
Permitted Radial Load	[N]	*7	1100	1100	1200	1200	1200	1200	1200		
Permitted Axial Load	[N]	*8	1000	1100	1100	1100	1100	1100	1100		
Maximum Radial Load	[N]	*9	1200								
Maximum Axial Load	[N]	*10	1100								
Moment of Inertia ($\leq \varnothing 8$)	[kgcm ²]	--	0.070	0.061	0.061	0.061	0.061	0.061	0.061		
Moment of Inertia ($\leq \varnothing 14$)	[kgcm ²]	--	0.115	0.106	0.106	0.105	0.105	0.105	0.105		
Efficiency	[%]	*11	88								
Torsional Rigidity	[Nm/arc-min]	*12	3								
Maximum Torsional Backlash	[arc-min]	--	≤ 7								
Noise Level	dB [A]	*13	≤ 80								
Protection Class	--	*14	IP54 (IP65)								
Ambient Temperature	[°C]	--	0-40								
Permitted Housing Temperature	[°C]	--	90								
Weight	[kg]	*15	1.6								

- *1) At nominal input speed, service life is 20,000 hours
- *2) The maximum torque when starting or stopping operation
- *3) The maximum torque allowed under a stress situation (Permitted 1,000 times during service life)
- *4) The average input speed
- *5) The maximum intermittent input speed
- *6) Torque at no load applied to the input shaft at nominal input speed
- *7) At this load and nominal input speed, service life will be 20,000 hours. (The radial load applied to the output side shaft center)
- *8) At this load and nominal input speed, service life will be 20,000 hours. (The axial load applied to the output side bearing)
- *9) The maximum radial load that the gearbox can accept
- *10) The maximum axial load that the gearbox can accept
- *11) The efficiency at the nominal output torque rating
- *12) This does not include lost motion
- *13) Contact NIDEC-SHIMPO for the testing conditions and environment
- *14) IP65 (wash-down) is available as an option. Contact NIDEC-SHIMPO for more details
- *15) The weight may vary slightly between models

EVB SERIES Right-angle Planetary

EVB o6o 2-Stage Dimensions

Input bore size $\leq \phi 8$ mm

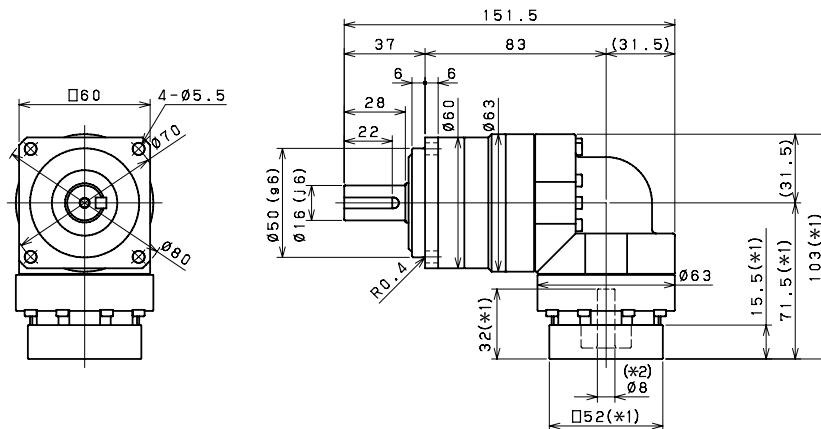

Input bore size $\leq \phi 14$ mm

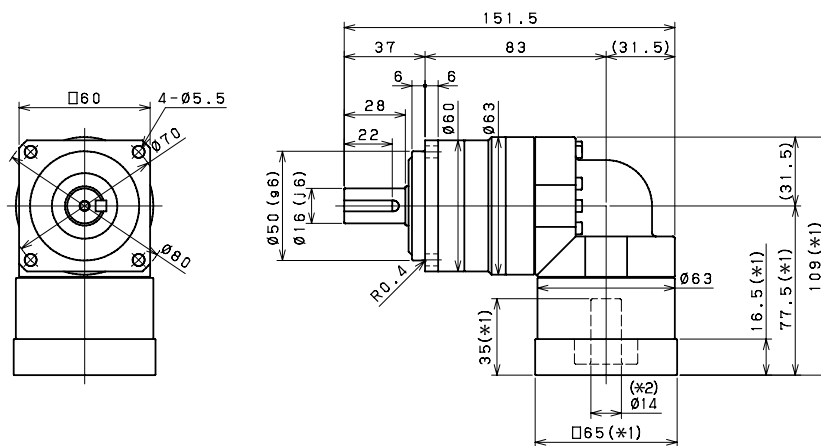

Input bore size $\leq \phi 19$ mm

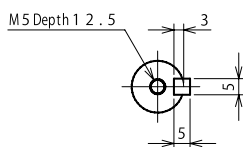
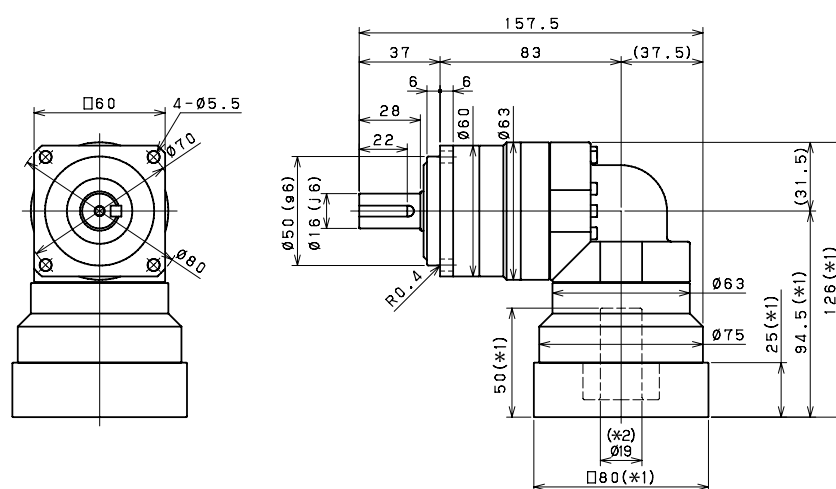

Keyed shaft

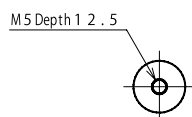

Smooth shaft

- *1) Length will vary depending on motor
- *2) Bushing will be inserted to adapt to motor shaft

EVB o6o 3-Stage Dimensions

Input bore size $\leq \phi 8$ mm

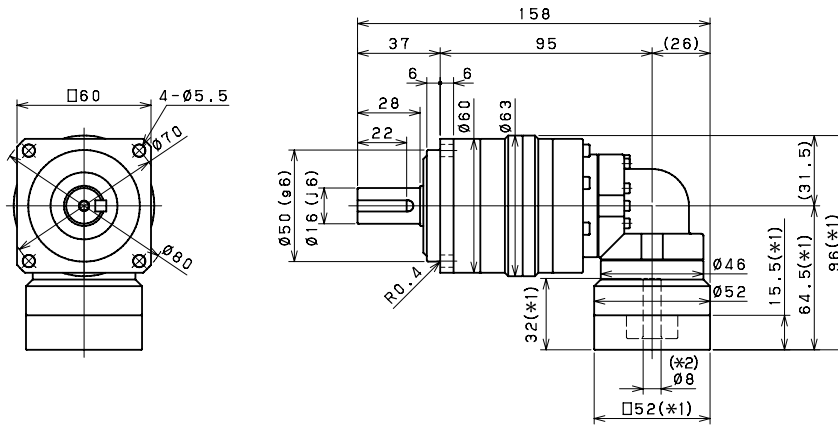

Input bore size $\leq \phi 14$ mm

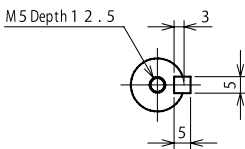
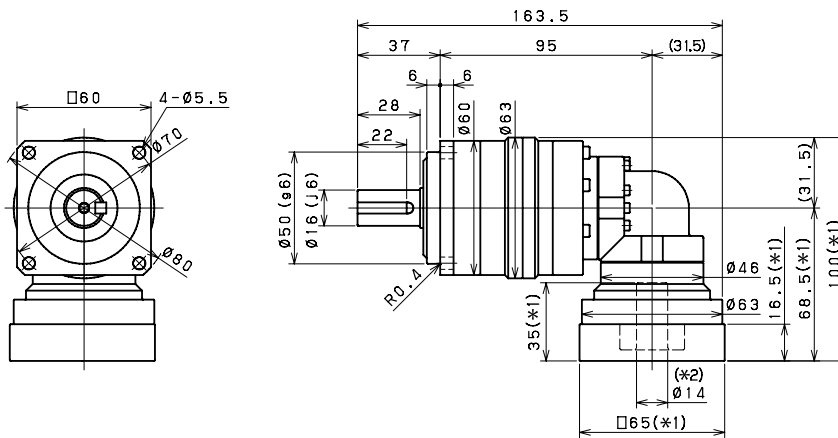

Keyed shaft

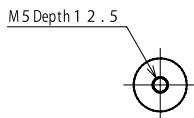

Smooth shaft

*1) Length will vary depending on motor

*2) Bushing will be inserted to adapt to motor shaft

EVB SERIES Right-angle Planetary

EVB o90 2-Stage Specifications

Frame Size	090									
Ratio	Unit	Note	3	4	5	6	7	8	9	10
Nominal Output Torque	[Nm]	*1	45	60	65	65	65	65	45	45
Maximum Acceleration Torque	[Nm]	*2	65	90	90	90	90	90	65	65
Emergency Stop Torque	[Nm]	*3	130	170	220	220	220	220	170	170
Nominal Input Speed	[rpm]	*4	3000							
Maximum Input Speed	[rpm]	*5	6000							
No Load Running Torque	[Nm]	*6	1.13							
Permitted Radial Load	[N]	*7	810	890	960	1000	1100	1100	1200	1200
Permitted Axial Load	[N]	*8	930	1100	1200	1300	1300	1400	1500	1600
Maximum Radial Load	[N]	*9	2400							
Maximum Axial Load	[N]	*10	2200							
Moment of Inertia ($\leq \varnothing 14$)	[kgcm ²]	--	2.120	1.890	1.800	1.760	1.730	1.710	1.700	1.690
Moment of Inertia ($\leq \varnothing 19$)	[kgcm ²]	--	2.450	2.220	2.130	2.090	2.060	2.040	2.030	2.020
Moment of Inertia ($\leq \varnothing 28$)	[kgcm ²]	--	4.570	4.350	4.260	4.210	4.180	4.170	4.160	4.150
Efficiency	[%]	*11	93							
Torsional Rigidity	[Nm/arc-min]	*12	10							
Maximum Torsional Backlash	[arc-min]	--	≤ 4							
Noise Level	dB [A]	*13	≤ 80							
Protection Class	--	*14	IP54 (IP65)							
Ambient Temperature	[°C]	--	0-40							
Permitted Housing Temperature	[°C]	--	90							
Weight	[kg]	*15	5.1							

EVB o90 3-Stage Specifications

Frame Size	090									
Ratio	Unit	Note	15	16	20	25	28	30	35	40
Nominal Output Torque	[Nm]	*1	45	65	65	65	65	45	65	65
Maximum Acceleration Torque	[Nm]	*2	65	110	110	110	110	65	110	110
Emergency Stop Torque	[Nm]	*3	170	220	220	220	220	170	220	220
Nominal Input Speed	[rpm]	*4	3000							
Maximum Input Speed	[rpm]	*5	6000							
No Load Running Torque	[Nm]	*6	0.55							
Permitted Radial Load	[N]	*7	1400	1400	1500	1600	1700	1700	1800	1900
Permitted Axial Load	[N]	*8	1900	1900	2100	2200	2200	2200	2200	2200
Maximum Radial Load	[N]	*9	2400							
Maximum Axial Load	[N]	*10	2200							
Moment of Inertia ($\leq \varnothing 8$)	[kgcm ²]	--	0.340	0.380	0.330	0.320	0.370	0.250	0.320	0.250
Moment of Inertia ($\leq \varnothing 14$)	[kgcm ²]	--	0.410	0.460	0.400	0.400	0.450	0.330	0.400	0.320
Moment of Inertia ($\leq \varnothing 19$)	[kgcm ²]	--	0.600	0.650	0.590	0.590	0.640	0.510	0.590	0.510
Efficiency	[%]	*11	88							
Torsional Rigidity	[Nm/arc-min]	*12	10							
Maximum Torsional Backlash	[arc-min]	--	≤ 7							
Noise Level	dB [A]	*13	≤ 80							
Protection Class	--	*14	IP54 (IP65)							
Ambient Temperature	[°C]	--	0-40							
Permitted Housing Temperature	[°C]	--	90							
Weight	[kg]	*15	4.4							

EVB 090 3-Stage Specifications

Frame Size	090										
Ratio	Unit	Note	45	50	60	70	80	90	100		
Nominal Output Torque	[Nm]	*1	45	65	65	65	65	45	45		
Maximum Acceleration Torque	[Nm]	*2	65	110	110	110	110	65	65		
Emergency Stop Torque	[Nm]	*3	170	220	220	220	220	170	170		
Nominal Input Speed	[rpm]	*4	3000								
Maximum Input Speed	[rpm]	*5	6000								
No Load Running Torque	[Nm]	*6	0.55								
Permitted Radial Load	[N]	*7	2000	2100	2200	2300	2400	2400	2400		
Permitted Axial Load	[N]	*8	2200	2200	2200	2200	2200	2200	2200		
Maximum Radial Load	[N]	*9	2400								
Maximum Axial Load	[N]	*10	2200								
Moment of Inertia ($\leq \varnothing 8$)	[kgcm ²]	--	0.320	0.250	0.250	0.250	0.250	0.250	0.250		
Moment of Inertia ($\leq \varnothing 14$)	[kgcm ²]	--	0.390	0.320	0.320	0.320	0.320	0.320	0.320		
Moment of Inertia ($\leq \varnothing 19$)	[kgcm ²]	--	0.580	0.510	0.510	0.510	0.510	0.510	0.510		
Efficiency	[%]	*11	88								
Torsional Rigidity	[Nm/arc-min]	*12	10								
Maximum Torsional Backlash	[arc-min]	--	≤ 7								
Noise Level	dB [A]	*13	≤ 80								
Protection Class	--	*14	IP54 (IP65)								
Ambient Temperature	[°C]	--	0-40								
Permitted Housing Temperature	[°C]	--	90								
Weight	[kg]	*15	4.4								

*1) At nominal input speed, service life is 20,000 hours

*2) The maximum torque when starting or stopping operation

*3) The maximum torque allowed under a stress situation (Permitted 1,000 times during service life)

*4) The average input speed

*5) The maximum intermittent input speed

*6) Torque at no load applied to the input shaft at nominal input speed

*7) At this load and nominal input speed, service life will be 20,000 hours. (The radial load applied to the output side shaft center)

*8) At this load and nominal input speed, service life will be 20,000 hours. (The axial load applied to the output side bearing)

*9) The maximum radial load that the gearbox can accept

*10) The maximum axial load that the gearbox can accept

*11) The efficiency at the nominal output torque rating

*12) This does not include lost motion

*13) Contact NIDEC-SHIMPO for the testing conditions and environment

*14) IP65 (wash-down) is available as an option. Contact NIDEC-SHIMPO for more details

*15) The weight may vary slightly between models

EVB SERIES Right-angle Planetary

EVB 090 2-Stage Dimensions

Input bore size $\leq \phi 14$ mm

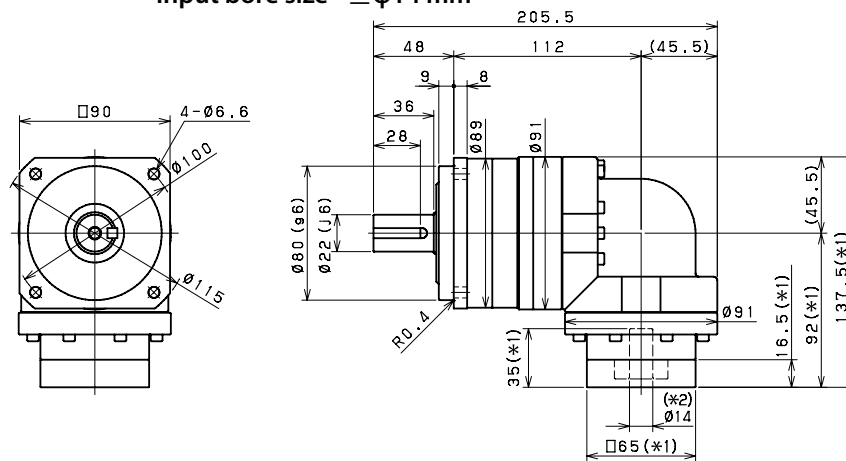

Input bore size $\leq \phi 19$ mm

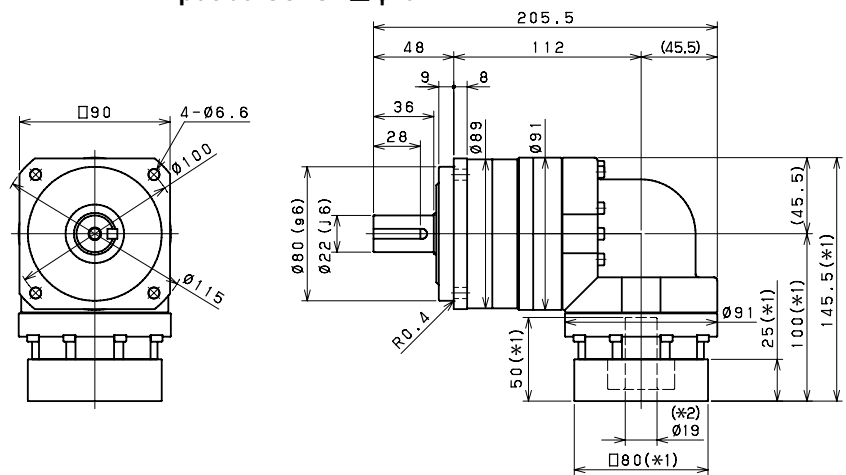

Input bore size $\leq \phi 28$ mm

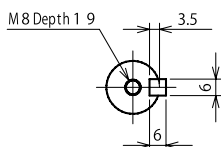
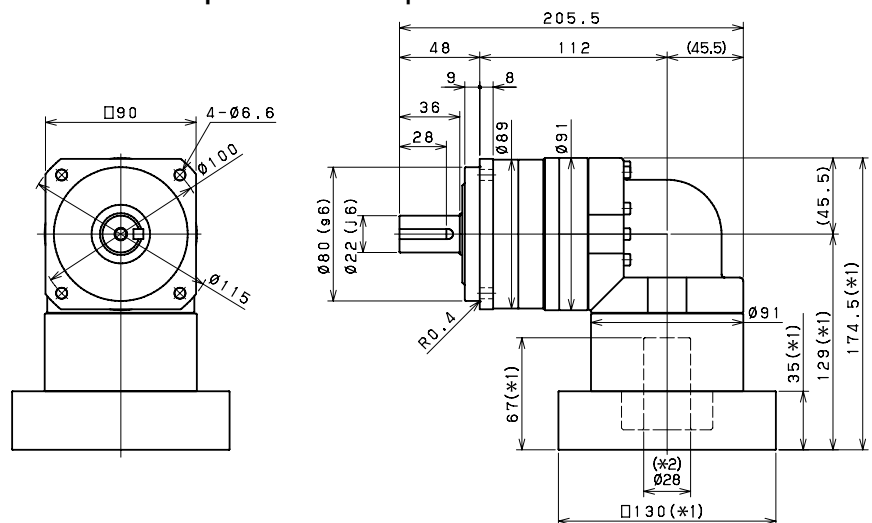

Keyed shaft

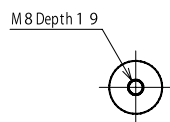

Smooth shaft

*1) Length will vary depending on motor

*2) Bushing will be inserted to adapt to motor shaft

EVb 090 3-Stage Dimensions

Input bore size $\leq \varnothing 8 \text{ mm}$

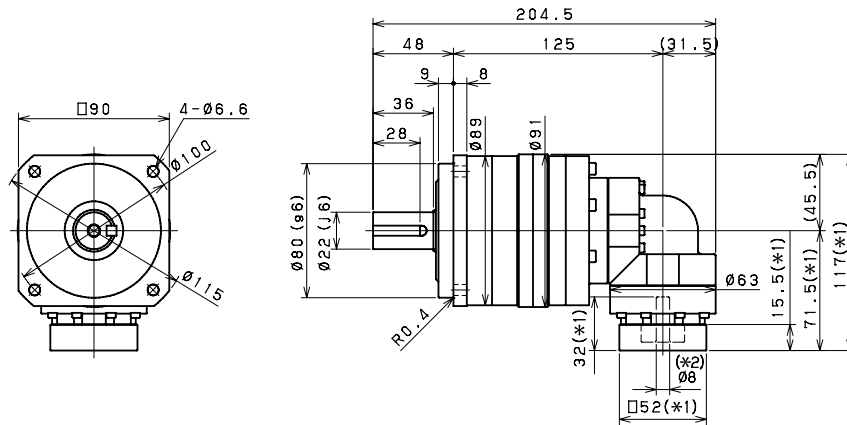

Input bore size $\leq \varnothing 14 \text{ mm}$

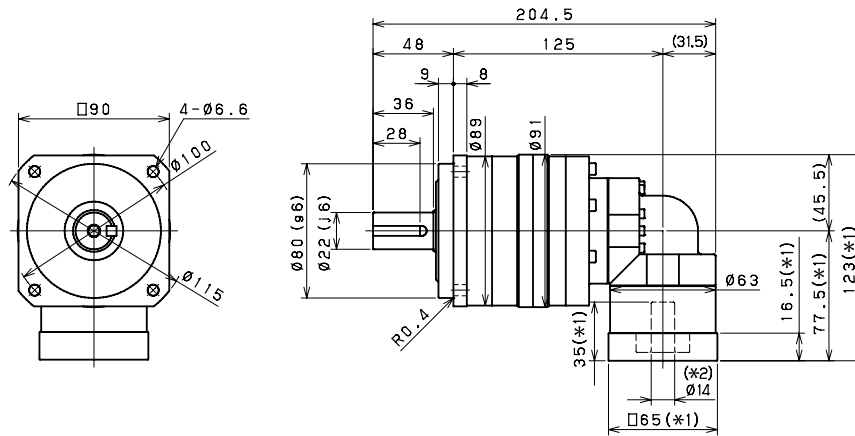

Input bore size $\leq \varnothing 19 \text{ mm}$

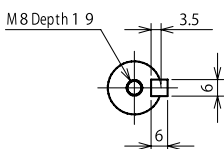
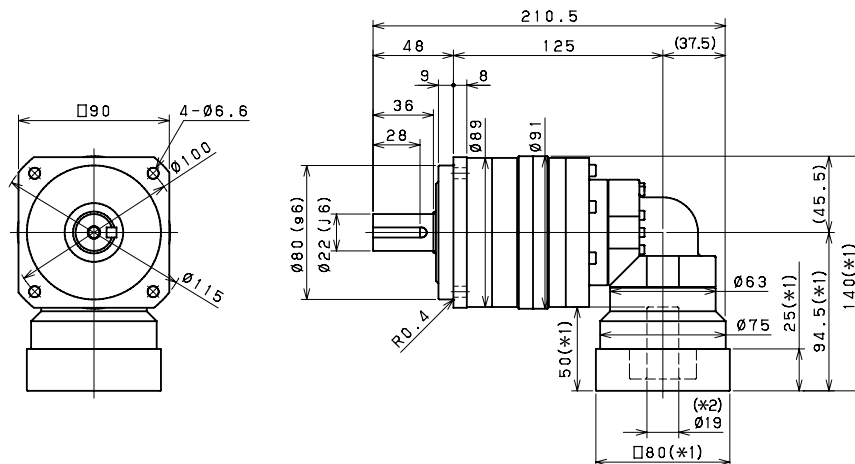

Keyed shaft

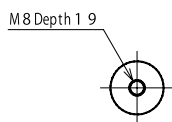

Smooth shaft

*1) Length will vary depending on motor

*2) Bushing will be inserted to adapt to motor shaft

EVB SERIES Right-angle Planetary

EVB 115 2-Stage Specifications

Frame Size	115									
Ratio	Unit	Note	3	4	5	6	7	8	9	10
Nominal Output Torque	[Nm]	*1	75	100	120	150	150	150	110	110
Maximum Acceleration Torque	[Nm]	*2	150	200	240	300	300	300	200	200
Emergency Stop Torque	[Nm]	*3	320	430	500	550	550	550	450	450
Nominal Input Speed	[rpm]	*4	3000							
Maximum Input Speed	[rpm]	*5	6000							
No Load Running Torque	[Nm]	*6	1.88							
Permitted Radial Load	[N]	*7	1300	1500	1600	1700	1800	1900	1900	2000
Permitted Axial Load	[N]	*8	1500	1700	1900	2000	2100	2300	2400	2500
Maximum Radial Load	[N]	*9	4300							
Maximum Axial Load	[N]	*10	3900							
Moment of Inertia ($\leq \varnothing 19$)	[kgcm ²]	--	6.740	5.490	5.020	4.770	4.650	4.550	4.490	4.460
Moment of Inertia ($\leq \varnothing 28$)	[kgcm ²]	--	8.340	7.080	6.610	6.360	6.240	6.140	6.080	6.050
Moment of Inertia ($\leq \varnothing 38$)	[kgcm ²]	--	15.410	14.150	13.690	13.430	13.310	13.220	13.160	13.120
Efficiency	[%]	*11	93							
Torsional Rigidity	[Nm/arc-min]	*12	31							
Maximum Torsional Backlash	[arc-min]	--	≤ 4							
Noise Level	dB [A]	*13	≤ 85							
Protection Class	--	*14	IP54 (IP65)							
Ambient Temperature	[°C]	--	0-40							
Permitted Housing Temperature	[°C]	--	90							
Weight	[kg]	*15	10.4							

EVB 115 3-Stage Specifications

Frame Size	115									
Ratio	Unit	Note	15	16	20	25	28	30	35	40
Nominal Output Torque	[Nm]	*1	110	130	150	150	150	110	150	150
Maximum Acceleration Torque	[Nm]	*2	200	260	300	300	300	200	300	300
Emergency Stop Torque	[Nm]	*3	450	550	550	550	550	450	550	550
Nominal Input Speed	[rpm]	*4	3000							
Maximum Input Speed	[rpm]	*5	6000							
No Load Running Torque	[Nm]	*6	1.11							
Permitted Radial Load	[N]	*7	2300	2300	2500	2700	2800	2900	3000	3200
Permitted Axial Load	[N]	*8	3000	3100	3400	3700	3900	3900	3900	3900
Maximum Radial Load	[N]	*9	3900							
Maximum Axial Load	[N]	*10	3900							
Moment of Inertia ($\leq \varnothing 14$)	[kgcm ²]	--	2.250	2.460	2.200	2.180	2.400	1.870	2.160	1.860
Moment of Inertia ($\leq \varnothing 19$)	[kgcm ²]	--	2.580	2.790	2.530	2.510	2.730	2.200	2.490	2.190
Moment of Inertia ($\leq \varnothing 28$)	[kgcm ²]	--	4.700	4.910	4.650	4.640	4.860	4.330	4.620	4.320
Efficiency	[%]	*11	88							
Torsional Rigidity	[Nm/arc-min]	*12	31							
Maximum Torsional Backlash	[arc-min]	--	≤ 7							
Noise Level	dB [A]	*13	≤ 85							
Protection Class	--	*14	IP54 (IP65)							
Ambient Temperature	[°C]	--	0-40							
Permitted Housing Temperature	[°C]	--	90							
Weight	[kg]	*15	10.1							

EVB 115 3-Stage Specifications

Frame Size	115										
Ratio	Unit	Note	45	50	60	70	80	90	100		
Nominal Output Torque	[Nm]	*1	110	150	150	150	150	110	110		
Maximum Acceleration Torque	[Nm]	*2	200	300	300	300	300	200	200		
Emergency Stop Torque	[Nm]	*3	450	550	550	550	550	450	450		
Nominal Input Speed	[rpm]	*4	3000								
Maximum Input Speed	[rpm]	*5	6000								
No Load Running Torque	[Nm]	*6	1.11								
Permitted Radial Load	[N]	*7	3300	3400	3600	3800	4000	4200	4300		
Permitted Axial Load	[N]	*8	3900	3900	3900	3900	3900	3900	3900		
Maximum Radial Load	[N]	*9	4300								
Maximum Axial Load	[N]	*10	3900								
Moment of Inertia ($\leq \varnothing 14$)	[kgcm ²]	--	2.150	1.860	1.850	1.850	1.850	1.850	1.850		
Moment of Inertia ($\leq \varnothing 19$)	[kgcm ²]	--	2.480	2.190	2.180	2.180	2.180	2.180	2.180		
Moment of Inertia ($\leq \varnothing 28$)	[kgcm ²]	--	4.610	4.310	4.310	4.310	4.310	4.310	4.310		
Efficiency	[%]	*11	88								
Torsional Rigidity	[Nm/arc-min]	*12	31								
Maximum Torsional Backlash	[arc-min]	--	≤ 7								
Noise Level	dB [A]	*13	≤ 85								
Protection Class	--	*14	IP54 (IP65)								
Ambient Temperature	[°C]	--	0-40								
Permitted Housing Temperature	[°C]	--	90								
Weight	[kg]	*15	10.1								

- *1) At nominal input speed, service life is 20,000 hours
- *2) The maximum torque when starting or stopping operation
- *3) The maximum torque allowed under a stress situation (Permitted 1,000 times during service life)
- *4) The average input speed
- *5) The maximum intermittent input speed
- *6) Torque at no load applied to the input shaft at nominal input speed
- *7) At this load and nominal input speed, service life will be 20,000 hours. (The radial load applied to the output side shaft center)
- *8) At this load and nominal input speed, service life will be 20,000 hours. (The axial load applied to the output side bearing)
- *9) The maximum radial load that the gearbox can accept
- *10) The maximum axial load that the gearbox can accept
- *11) The efficiency at the nominal output torque rating
- *12) This does not include lost motion
- *13) Contact NIDEC-SHIMPO for the testing conditions and environment
- *14) IP65 (wash-down) is available as an option. Contact NIDEC-SHIMPO for more details
- *15) The weight may vary slightly between models

EVB SERIES Right-angle Planetary

EVB 115 2-Stage Dimensions

Input bore size $\leq \phi 19$ mm

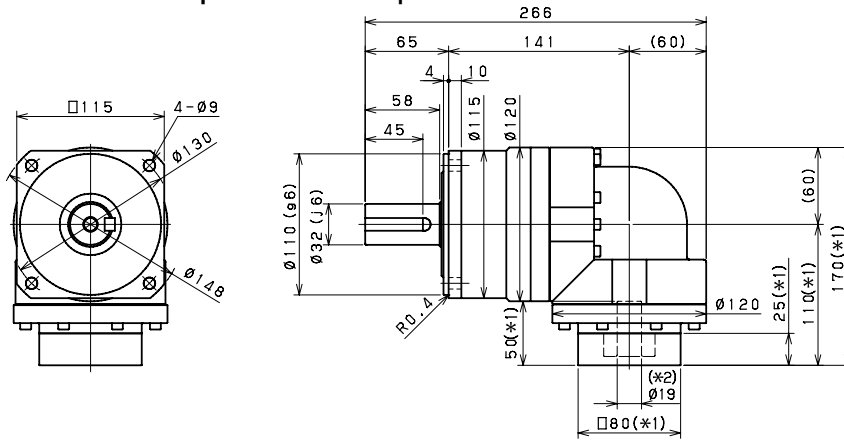

Input bore size $\leq \phi 28$ mm

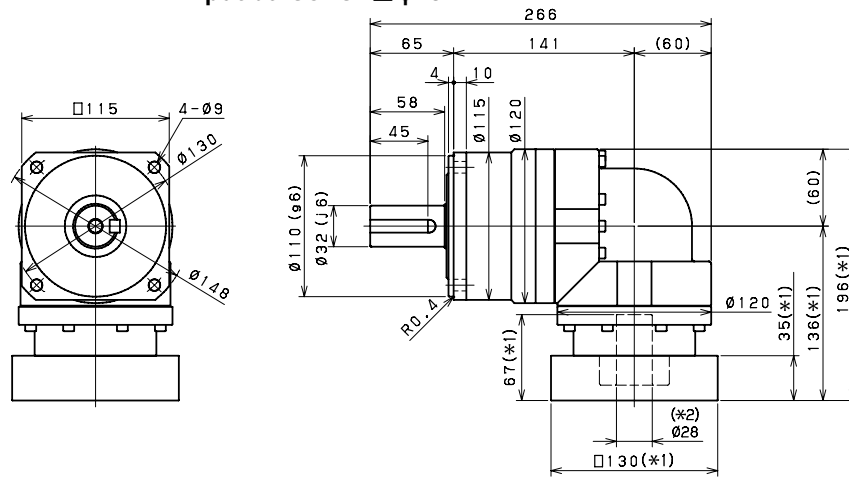

Input bore size $\leq \phi 38$ mm

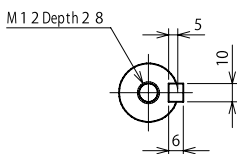
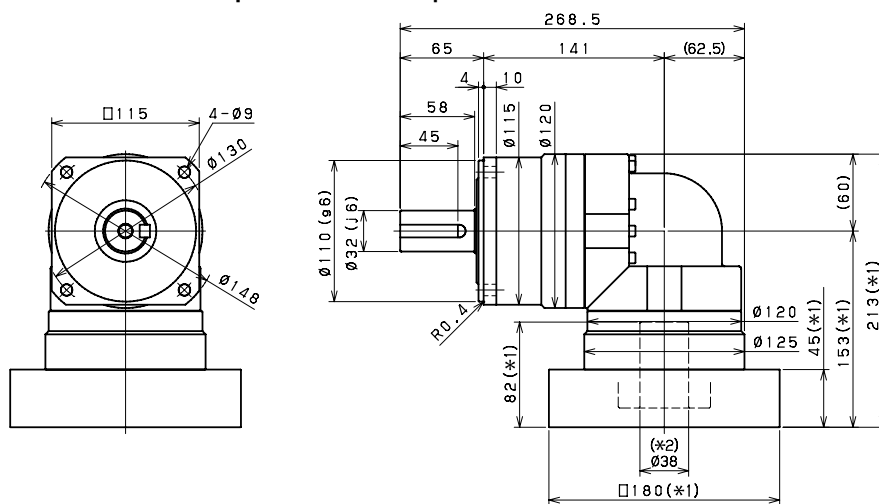

Keyed shaft

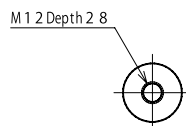

Smooth shaft

*1) Length will vary depending on motor

*2) Bushing will be inserted to adapt to motor shaft

EVB 115 3-Stage Dimensions

Input bore size $\leq \phi 14$ mm

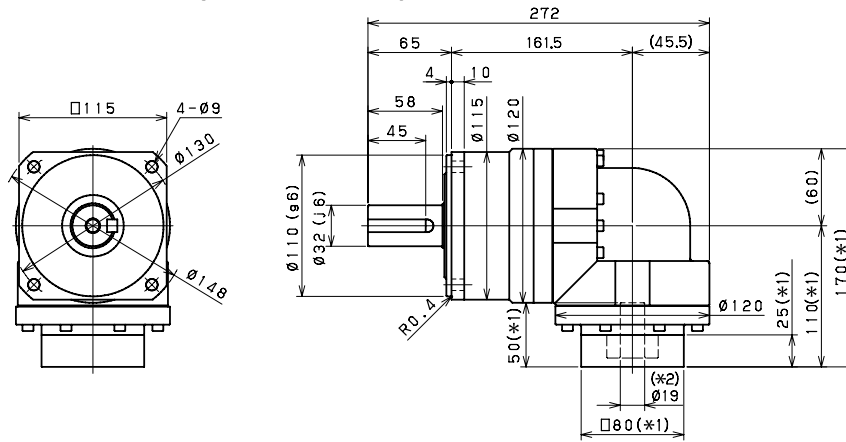

Input bore size $\leq \phi 19$ mm

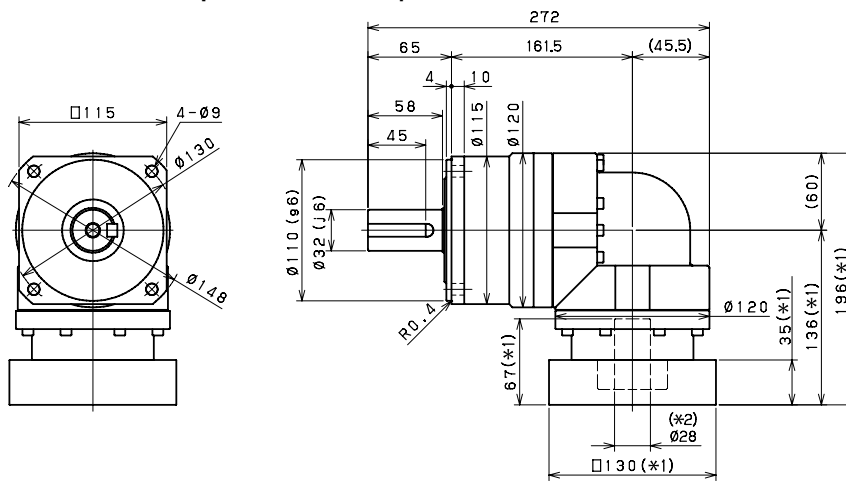

Input bore size $\leq \phi 28$ mm

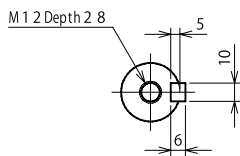
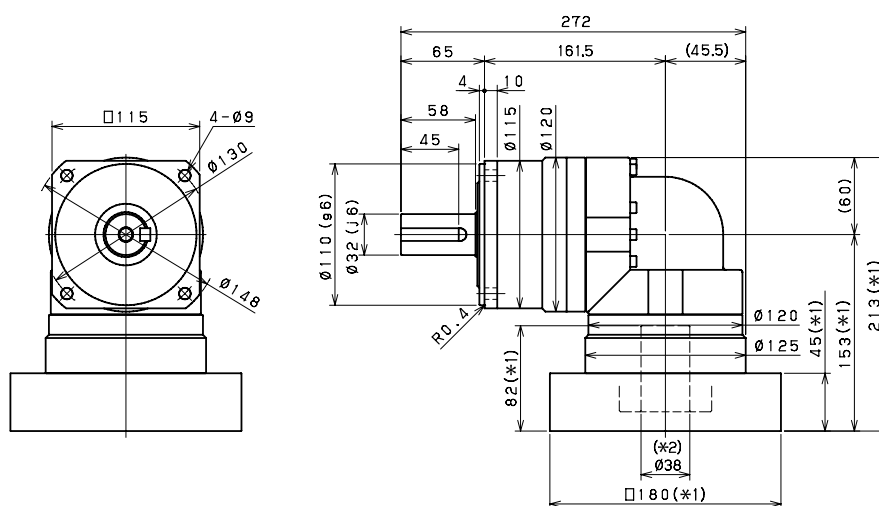

Keyed shaft

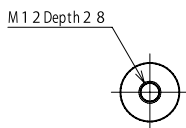

Smooth shaft

*1) Length will vary depending on motor

*2) Bushing will be inserted to adapt to motor shaft

EVB SERIES Right-angle Planetary

EVB 140 2-Stage Specifications

Frame Size	140									
Ratio	Unit	Note	3	4	5	6	7	8	9	10
Nominal Output Torque	[Nm]	*1	130	170	200	260	300	300	200	200
Maximum Acceleration Torque	[Nm]	*2	260	340	400	520	600	600	400	400
Emergency Stop Torque	[Nm]	*3	700	950	1100	1100	1100	1100	750	750
Nominal Input Speed	[rpm]	*4	2000							
Maximum Input Speed	[rpm]	*5	4000							
No Load Running Torque	[Nm]	*6	3.26							
Permitted Radial Load	[N]	*7	3200	3500	3800	4000	4200	4400	4600	4700
Permitted Axial Load	[N]	*8	2400	2700	3000	3300	3500	3700	3900	4100
Maximum Radial Load	[N]	*9	9100							
Maximum Axial Load	[N]	*10	8200							
Moment of Inertia ($\leq \varnothing 28$)	[kgcm ²]	--	23.130	18.570	16.910	16.010	15.580	15.230	14.770	14.660
Moment of Inertia ($\leq \varnothing 38$)	[kgcm ²]	--	27.500	22.940	21.280	20.380	19.950	19.610	19.410	19.030
Moment of Inertia ($\leq \varnothing 48$)	[kgcm ²]	--	40.730	36.170	34.510	33.610	33.180	32.840	32.370	32.260
Efficiency	[%]	*11	93							
Torsional Rigidity	[Nm/arc-min]	*12	60							
Maximum Torsional Backlash	[arc-min]	--	≤ 4							
Noise Level	dB [A]	*13	≤ 85							
Protection Class	--	*14	IP54 (IP65)							
Ambient Temperature	[°C]	--	0-40							
Permitted Housing Temperature	[°C]	--	90							
Weight	[kg]	*15	19.1							

EVB 140 3-Stage Specifications

Frame Size	140									
Ratio	Unit	Note	15	16	20	25	28	30	35	40
Nominal Output Torque	[Nm]	*1	200	300	300	300	300	200	300	300
Maximum Acceleration Torque	[Nm]	*2	400	600	600	600	600	400	600	600
Emergency Stop Torque	[Nm]	*3	750	1100	1100	1100	1100	750	1100	1100
Nominal Input Speed	[rpm]	*4	2000							
Maximum Input Speed	[rpm]	*5	4000							
No Load Running Torque	[Nm]	*6	2.56							
Permitted Radial Load	[N]	*7	5400	5500	6000	6400	6700	6800	7200	7500
Permitted Axial Load	[N]	*8	4900	5000	5500	6100	6400	6600	7000	7500
Maximum Radial Load	[N]	*9	9100							
Maximum Axial Load	[N]	*10	8200							
Moment of Inertia ($\leq \varnothing 19$)	[kgcm ²]	--	6.400	7.290	6.220	6.150	7.090	4.990	6.090	4.950
Moment of Inertia ($\leq \varnothing 28$)	[kgcm ²]	--	8.000	8.880	7.810	7.750	8.680	6.580	7.690	6.540
Moment of Inertia ($\leq \varnothing 38$)	[kgcm ²]	--	15.070	15.960	14.890	14.820	15.760	13.660	14.760	13.610
Efficiency	[%]	*11	88							
Torsional Rigidity	[Nm/arc-min]	*12	60							
Maximum Torsional Backlash	[arc-min]	--	≤ 7							
Noise Level	dB [A]	*13	≤ 85							
Protection Class	--	*14	IP54 (IP65)							
Ambient Temperature	[°C]	--	0-40							
Permitted Housing Temperature	[°C]	--	90							
Weight	[kg]	*15	19.6							

EVB 140 3-Stage Specifications

Frame Size	140										
Ratio	Unit	Note	45	50	60	70	80	90	100		
Nominal Output Torque	[Nm]	*1	200	300	300	300	300	200	200		
Maximum Acceleration Torque	[Nm]	*2	400	600	600	600	600	400	400		
Emergency Stop Torque	[Nm]	*3	750	1100	1100	1100	1100	750	750		
Nominal Input Speed	[rpm]	*4	2000								
Maximum Input Speed	[rpm]	*5	4000								
No Load Running Torque	[Nm]	*6	2.56								
Permitted Radial Load	[N]	*7	7800	8100	8600	9100	9100	9100	9100		
Permitted Axial Load	[N]	*8	7900	8200	8200	8200	8200	8200	8200		
Maximum Radial Load	[N]	*9	9100								
Maximum Axial Load	[N]	*10	8200								
Moment of Inertia (≤ Ø 19)	[kgcm ²]	--	6.070	4.930	4.920	4.910	4.910	4.910	4.910		
Moment of Inertia (≤ Ø 28)	[kgcm ²]	--	7.660	6.520	6.510	6.510	6.500	6.500	6.500		
Moment of Inertia (≤ Ø 38)	[kgcm ²]	--	14.740	13.590	13.590	13.580	13.580	13.570	13.570		
Efficiency	[%]	*11	88								
Torsional Rigidity	[Nm/arc-min]	*12	60								
Maximum Torsional Backlash	[arc-min]	--	≤ 7								
Noise Level	dB [A]	*13	≤ 85								
Protection Class	--	*14	IP54 (IP65)								
Ambient Temperature	[°C]	--	0-40								
Permitted Housing Temperature	[°C]	--	90								
Weight	[kg]	*15	19.6								

- *1) At nominal input speed, service life is 20,000 hours
- *2) The maximum torque when starting or stopping operation
- *3) The maximum torque allowed under a stress situation (Permitted 1,000 times during service life)
- *4) The average input speed
- *5) The maximum intermittent input speed
- *6) Torque at no load applied to the input shaft at nominal input speed
- *7) At this load and nominal input speed, service life will be 20,000 hours. (The radial load applied to the output side shaft center)
- *8) At this load and nominal input speed, service life will be 20,000 hours. (The axial load applied to the output side bearing)
- *9) The maximum radial load that the gearbox can accept
- *10) The maximum axial load that the gearbox can accept
- *11) The efficiency at the nominal output torque rating
- *12) This does not include lost motion
- *13) Contact NIDEC-SHIMPO for the testing conditions and environment
- *14) IP65 (wash-down) is available as an option. Contact NIDEC-SHIMPO for more details
- *15) The weight may vary slightly between models

EVB SERIES Right-angle Planetary

EVB 140 2-Stage Dimensions

Input bore size $\leq \varnothing 28$ mm

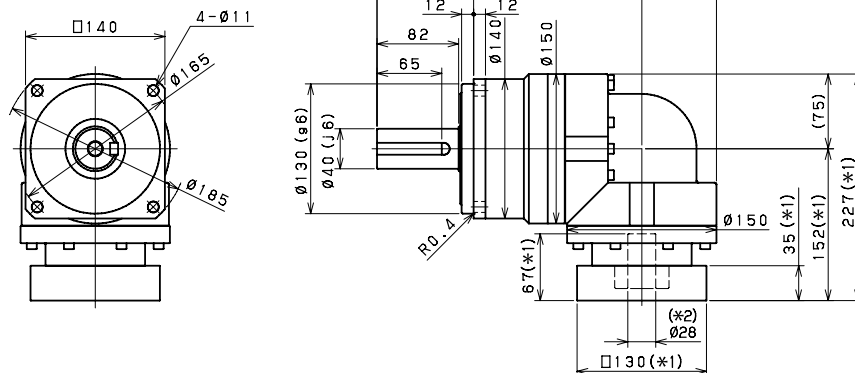

Input bore size $\leq \varnothing 38$ mm

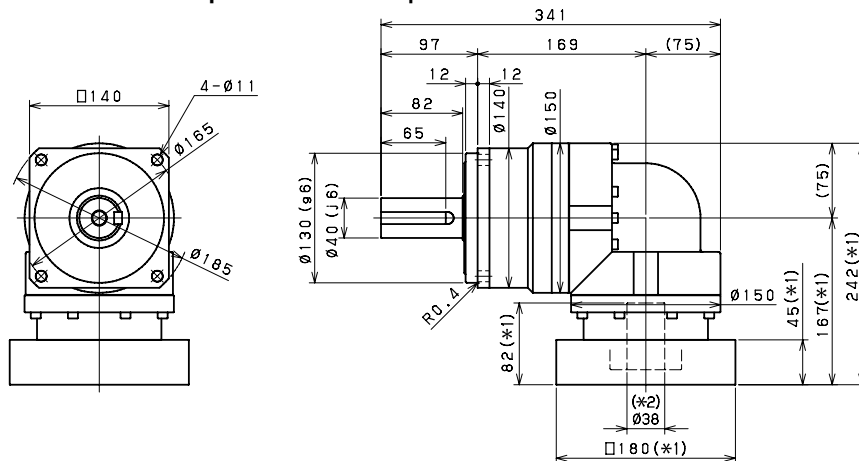

Input bore size $\leq \varnothing 48$ mm

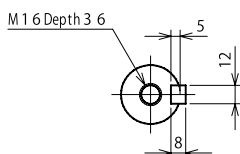
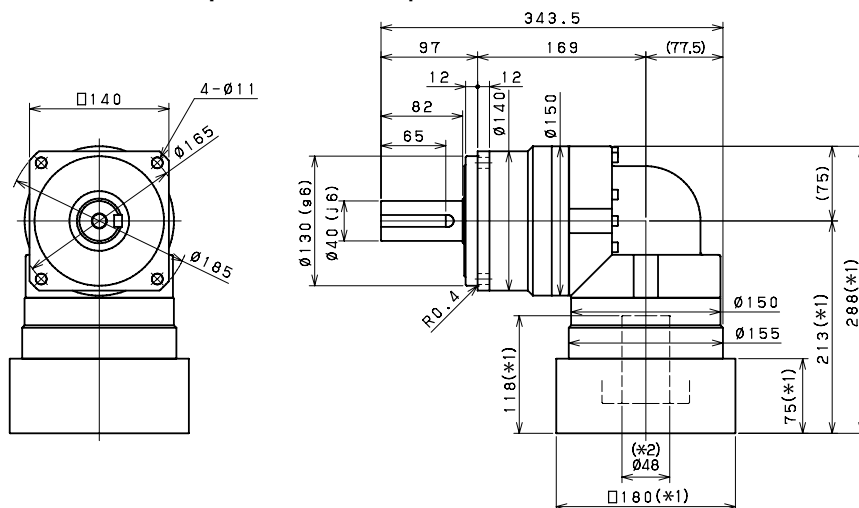

Keyed shaft

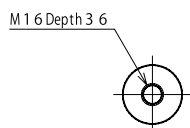

Smooth shaft

*1) Length will vary depending on motor

*2) Bushing will be inserted to adapt to motor shaft

EVB 140 3-Stage Dimensions

Input bore size $\leq \phi 19$ mm

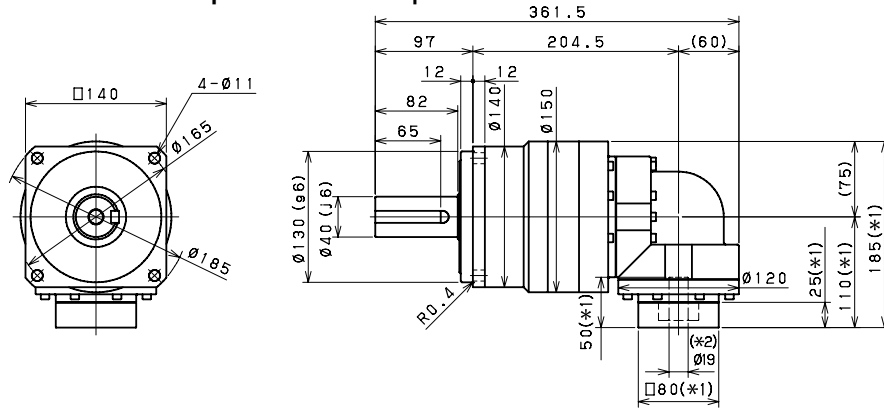

Input bore size $\leq \phi 28$ mm

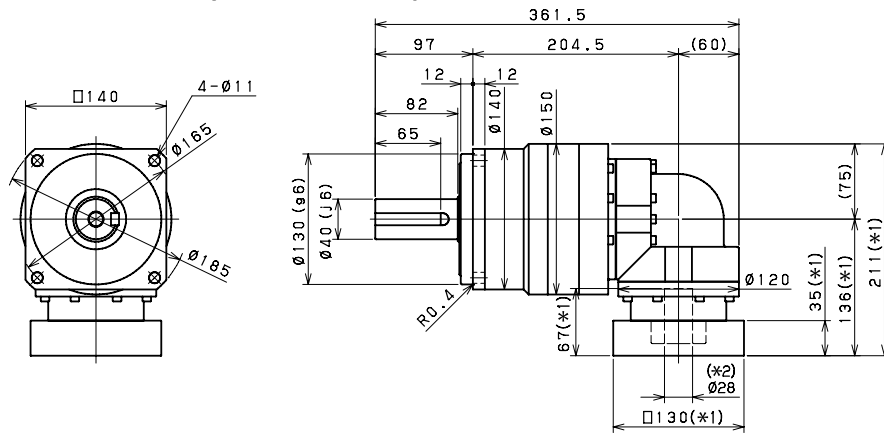

Input bore size $\leq \phi 38$ mm

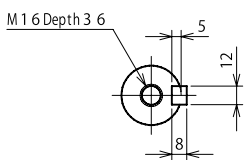
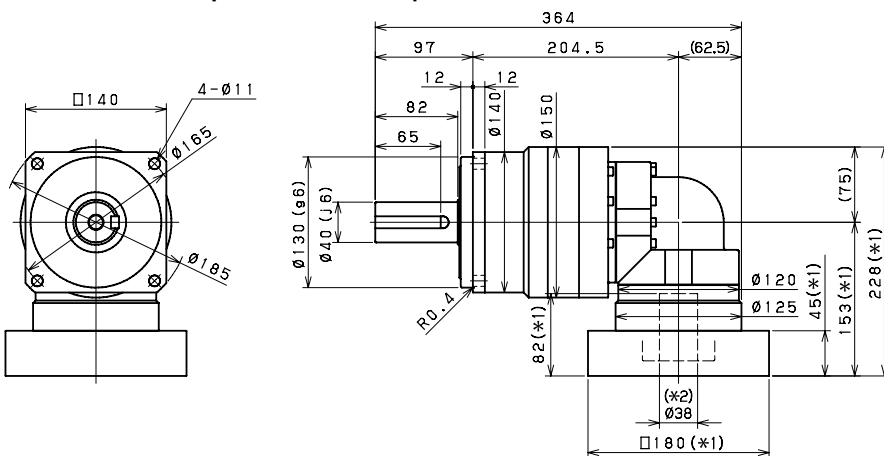

Keyed shaft

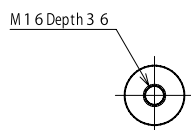

Smooth shaft

*1) Length will vary depending on motor

*2) Bushing will be inserted to adapt to motor shaft

EVB SERIES Right-angle Planetary

EVB 180 2-Stage Specifications

Frame Size	180									
Ratio	Units	Note	3	4	5	6	7	8	9	10
Nominal Output Torque	[Nm]	*1	400	575	600	600	600	600	400	400
Maximum Acceleration Torque	[Nm]	*2	575	770	960	1120	1120	1120	775	775
Emergency Stop Torque	[Nm]	*3	1300	1700	2000	2500	2500	2500	2000	2000
Nominal Input Speed	[rpm]	*4	1500							
Maximum Input Speed	[rpm]	*5	3000							
No Load Running Torque	[Nm]	*6	10.8							
Permitted Radial Load	[N]	*7	5600	6200	6700	7100	7400	7800	8100	8400
Permitted Axial Load	[N]	*8	4300	4900	5400	5800	6300	6600	7000	7300
Maximum Radial Load	[N]	*9	15000							
Maximum Axial Load	[N]	*10	14000							
Moment of Inertia ($\leq \emptyset 38$)	[kgcm ²]	--	93.71	77.72	71.89	68.74	66.43	65.27	64.60	64.28
Moment of Inertia ($\leq \emptyset 48$)	[kgcm ²]	--	128.6	112.6	106.8	103.6	101.3	100.1	99.46	99.14
Moment of Inertia ($\leq \emptyset 65$)	[kgcm ²]	--	214.2	198.2	192.4	189.2	186.9	185.7	185.1	184.7
Efficiency	[%]	*11	93							
Torsional Rigidity	[Nm/arcmin]	*12	175							
Maximum Torsional Backlash	[Arc-min]	--	≤ 6							
Noise Level	dB [A]	*13	≤ 85							
Protection Class	--	*14	IP54 (IP65)							
Ambient Temperature	[°C]	--	0-40							
Permitted Housing Temperature	[°C]	--	90							
Weight	[kg]	*15	49							

EVB 180 3-Stage Specifications

Frame Size	180									
Ratio	Units	Note	15	16	20	25	28	30	35	40
Nominal Output Torque	[Nm]	*1	400	555	600	600	600	400	600	600
Maximum Acceleration Torque	[Nm]	*2	775	1120	1120	1120	1120	775	1120	1120
Emergency Stop Torque	[Nm]	*3	2000	2500	2500	2500	2500	2000	2500	2500
Nominal Input Speed	[rpm]	*4	1500							
Maximum Input Speed	[rpm]	*5	3000							
No Load Running Torque	[Nm]	*6	4.7							
Permitted Radial Load	[N]	*7	9600	9800	11000	11000	12000	12000	13000	13000
Permitted Axial Load	[N]	*8	8700	8900	9900	11000	11000	12000	13000	13000
Maximum Radial Load	[N]	*9	15000							
Maximum Axial Load	[N]	*10	14000							
Moment of Inertia ($\leq \emptyset 28$)	[kgcm ²]	--	11.49	12.09	11.15	10.98	11.59	10.33	10.83	10.24
Moment of Inertia ($\leq \emptyset 38$)	[kgcm ²]	--	20.28	20.88	19.94	19.77	20.38	19.11	19.62	19.03
Moment of Inertia ($\leq \emptyset 48$)	[kgcm ²]	--	25.10	25.70	24.76	24.59	25.20	23.94	24.44	23.85
Efficiency	[%]	*11	88							
Torsional Rigidity	[Nm/arcmin]	*12	175							
Maximum Torsional Backlash	[Arc-min]	--	≤ 9							
Noise Level	dB [A]	*13	≤ 85							
Protection Class	--	*14	IP54 (IP65)							
Ambient Temperature	[°C]	--	0-40							
Permitted Housing Temperature	[°C]	--	90							
Weight	[kg]	*15	36							

EVB 180 3-Stage Specifications

Frame Size	180										
Ratio	Units	Note	45	50	60	70	80	90	100		
Nominal Output Torque	[Nm]	*1	400	600	600	600	600	400	400		
Maximum Acceleration Torque	[Nm]	*2	775	1120	1120	1120	1120	775	775		
Emergency Stop Torque	[Nm]	*3	2000	2500	2500	2500	2500	2000	2000		
Nominal Input Speed	[rpm]	*4	1500								
Maximum Input Speed	[rpm]	*5	3000								
No Load Running Torque	[Nm]	*6	4.7								
Permitted Radial Load	[N]	*7	14000	14000	15000	15000	15000	15000	15000		
Permitted Axial Load	[N]	*8	14000	14000	14000	14000	14000	14000	14000		
Maximum Radial Load	[N]	*9	15000								
Maximum Axial Load	[N]	*10	14000								
Moment of Inertia ($\leq \varnothing 28$)	[kgcm ²]	--	10.76	10.20	10.18	10.16	10.15	10.15	10.14		
Moment of Inertia ($\leq \varnothing 38$)	[kgcm ²]	--	19.55	18.99	18.96	18.95	18.94	18.93	18.93		
Moment of Inertia ($\leq \varnothing 48$)	[kgcm ²]	--	24.37	23.81	23.78	23.77	23.76	23.75	23.75		
Efficiency	[%]	*11	88								
Torsional Rigidity	[Nm/arcmin]	*12	175								
Maximum Torsional Backlash	[Arc-min]	--	≤ 9								
Noise Level	dB [A]	*13	≤ 85								
Protection Class	--	*14	IP54 (IP65)								
Ambient Temperature	[°C]	--	0-40								
Permitted Housing Temperature	[°C]	--	90								
Weight	[kg]	*15	36								

- *1) At nominal input speed, service life is 20,000 hours
- *2) The maximum torque when starting or stopping operation
- *3) The maximum torque allowed under a stress situation (Permitted 1,000 times during service life)
- *4) The average input speed
- *5) The maximum intermittent input speed
- *6) Torque at no load applied to the input shaft at nominal input speed
- *7) At this load and nominal input speed, service life will be 20,000 hours. (The radial load applied to the output side shaft center)
- *8) At this load and nominal input speed, service life will be 20,000 hours. (The axial load applied to the output side bearing)
- *9) The maximum radial load that the gearbox can accept
- *10) The maximum axial load that the gearbox can accept
- *11) The efficiency at the nominal output torque rating
- *12) This does not include lost motion
- *13) Contact NIDEC-SHIMPO for the testing conditions and environment
- *14) IP65 (wash-down) is available as an option. Contact NIDEC-SHIMPO for more details
- *15) The weight may vary slightly between models

EVB SERIES Right-angle Planetary

EVB 180 2-Stage Dimensions

Input bore size $\leq \varnothing 38$ mm

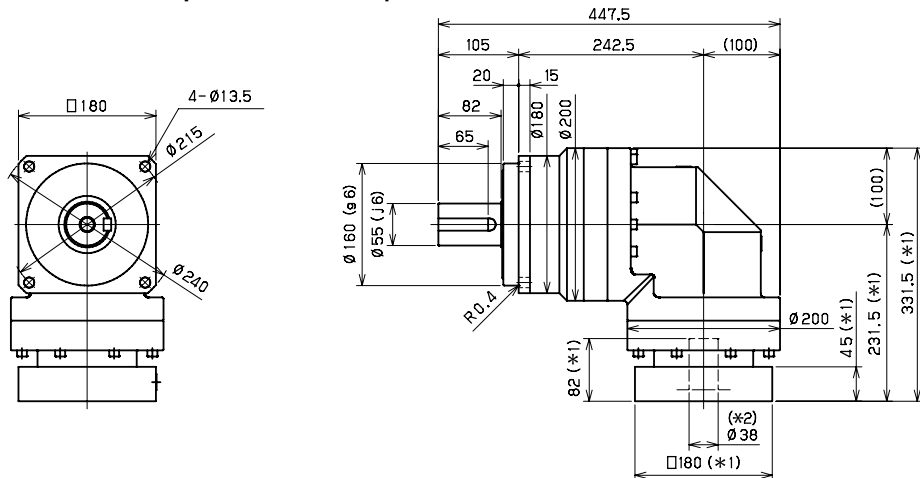

Input bore size $\leq \varnothing 48$ mm

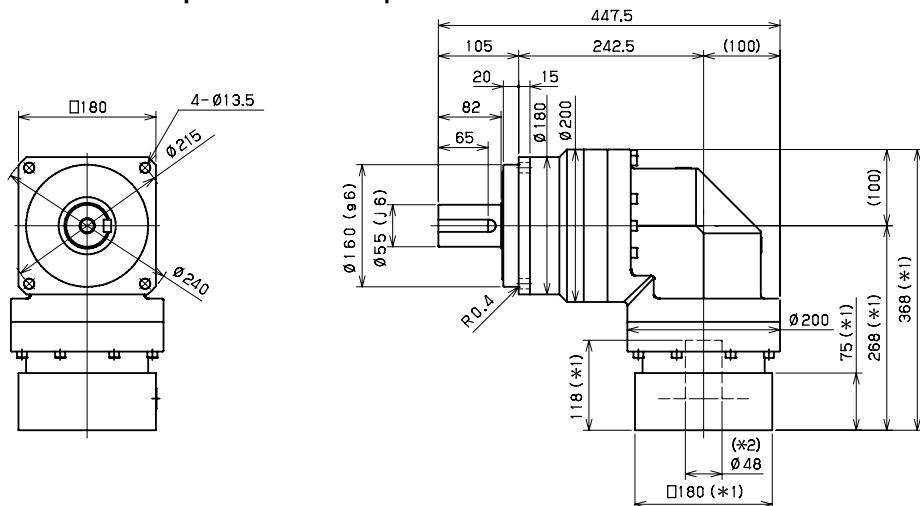

Input bore size $\leq \varnothing 65$ mm

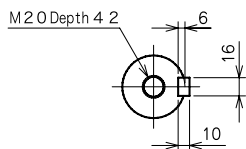
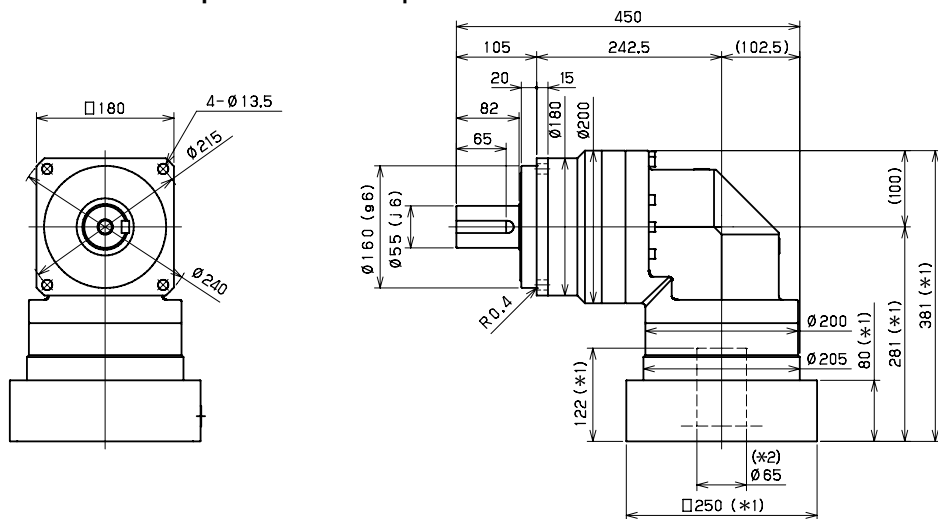

Keyed shaft

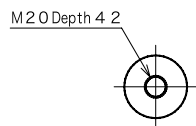

Smooth shaft

*1) Length will vary depending on motor

*2) Bushing will be inserted to adapt to motor shaft

EVB 180 3-Stage Dimensions

Input bore size $\leq \varnothing 28$ mm

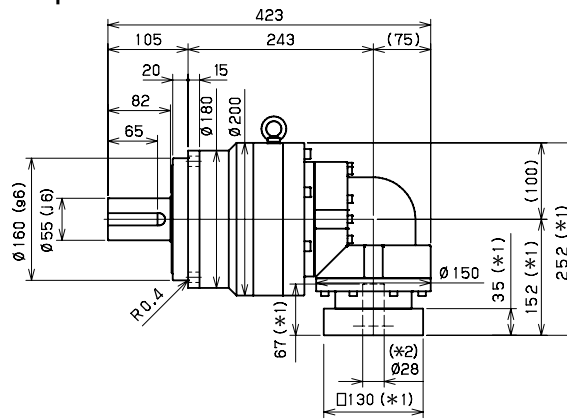
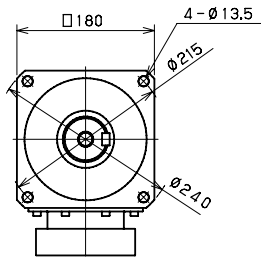

Input bore size $\leq \varnothing 38$ mm

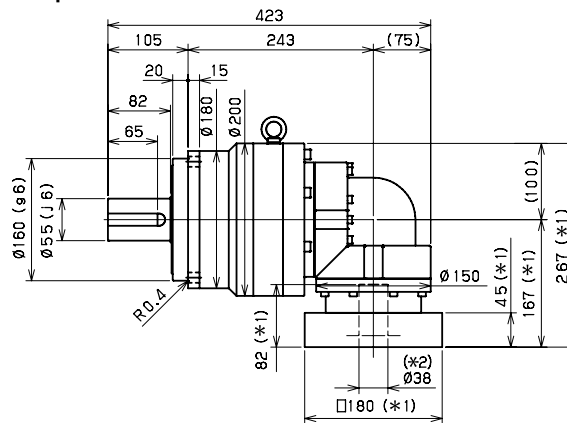
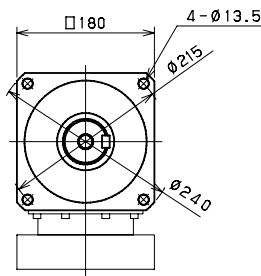

Input bore size $\leq \varnothing 48$ mm

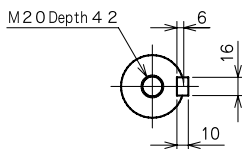
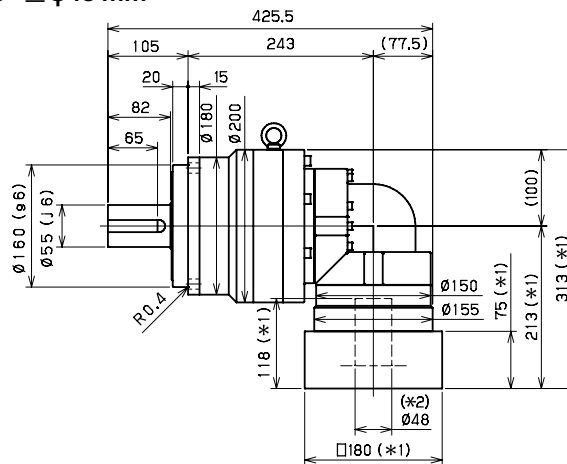
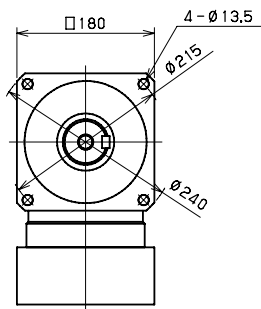

Keyed shaft

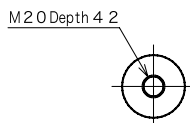

Smooth shaft

*1) Length will vary depending on motor

*2) Bushing will be inserted to adapt to motor shaft

EVB SERIES Right-angle Planetary

EVB 220 2-Stage Specifications

Frame Size	220									
Ratio	Units	Note	3	4	5	6	7	8	9	10
Nominal Output Torque	[Nm]	*1	575	765	960	1150	1200	1200	800	800
Maximum Acceleration Torque	[Nm]	*2	1015	1355	1695	1840	1840	1760	1520	1280
Emergency Stop Torque	[Nm]	*3	2500	3300	4000	4500	4500	4500	3600	3600
Nominal Input Speed	[rpm]	*4	1000							
Maximum Input Speed	[rpm]	*5	2000							
No Load Running Torque	[Nm]	*6	14.5							
Permitted Radial Load	[N]	*7	5800	6400	6900	7300	7700	8000	8400	8700
Permitted Axial Load	[N]	*8	6400	7200	7900	8600	9200	9700	10000	11000
Maximum Radial Load	[N]	*9	15000							
Maximum Axial Load	[N]	*10	14000							
Moment of Inertia ($\leq \varnothing 48$)	[kgcm ²]	--	148.0	122.9	113.3	108.1	104.7	102.7	101.6	101.0
Moment of Inertia ($\leq \varnothing 65$)	[kgcm ²]	--	223.2	198.1	188.6	183.3	180.0	178.0	176.8	176.2
Efficiency	[%]	*11	93							
Torsional Rigidity	[Nm/arcmin]	*12	400							
Maximum Torsional Backlash	[Arc-min]	--	≤ 6							
Noise Level	dB [A]	*13	≤ 85							
Protection Class	--	*14	IP54 (IP65)							
Ambient Temperature	[°C]	--	0-40							
Permitted Housing Temperature	[°C]	--	90							
Weight	[kg]	*15	66							

EVB 220 3-Stage Specifications

Frame Size	220									
Ratio	Units	Note	15	16	20	25	28	30	35	40
Nominal Output Torque	[Nm]	*1	800	1200	1200	1200	1200	800	1200	1200
Maximum Acceleration Torque	[Nm]	*2	1280	1840	1840	1840	1840	1280	1840	1840
Emergency Stop Torque	[Nm]	*3	3600	4500	4500	4500	4500	3600	4500	4500
Nominal Input Speed	[rpm]	*4	1000							
Maximum Input Speed	[rpm]	*5	2000							
No Load Running Torque	[Nm]	*6	10.2							
Permitted Radial Load	[N]	*7	9900	10000	11000	12000	12000	13000	13000	14000
Permitted Axial Load	[N]	*8	13000	13000	14000	14000	14000	14000	14000	14000
Maximum Radial Load	[N]	*9	15000							
Maximum Axial Load	[N]	*10	14000							
Moment of Inertia ($\leq \varnothing 38$)	[kgcm ²]	--	36.32	37.24	35.75	35.47	36.39	34.39	35.21	34.25
Moment of Inertia ($\leq \varnothing 48$)	[kgcm ²]	--	66.14	67.06	65.57	65.28	66.21	64.21	65.03	64.07
Efficiency	[%]	*11	88							
Torsional Rigidity	[Nm/arcmin]	*12	400							
Maximum Torsional Backlash	[Arc-min]	--	≤ 9							
Noise Level	dB [A]	*13	≤ 85							
Protection Class	--	*14	IP54 (IP65)							
Ambient Temperature	[°C]	--	0-40							
Permitted Housing Temperature	[°C]	--	90							
Weight	[kg]	*15	67							

EVB 220 3-Stage Specifications

Frame Size	220										
Ratio	Units	Note	45	50	60	70	80	90	100		
Nominal Output Torque	[Nm]	*1	800	1200	1200	1200	1200	800	800		
Maximum Acceleration Torque	[Nm]	*2	1040	1840	1840	1840	1440	1040	960		
Emergency Stop Torque	[Nm]	*3	3600	4500	4500	4500	4500	3600	3600		
Nominal Input Speed	[rpm]	*4	1000								
Maximum Input Speed	[rpm]	*5	2000								
No Load Running Torque	[Nm]	*6	10.2								
Permitted Radial Load	[N]	*7	14000	15000	15000	15000	15000	15000	15000		
Permitted Axial Load	[N]	*8	14000	14000	14000	14000	14000	14000	14000		
Maximum Radial Load	[N]	*9	15000								
Maximum Axial Load	[N]	*10	14000								
Moment of Inertia (≤Ø 38)	[kgcm ²]	--	35.10	34.18	34.14	34.11	34.10	34.09	34.08		
Moment of Inertia (≤Ø 48)	[kgcm ²]	--	64.92	63.99	63.95	63.93	63.91	63.90	63.90		
Efficiency	[%]	*11	88								
Torsional Rigidity	[Nm/arcmin]	*12	400								
Maximum Torsional Backlash	[Arc-min]	--	≤ 9								
Noise Level	dB [A]	*13	≤ 85								
Protection Class	--	*14	IP54 (IP65)								
Ambient Temperature	[°C]	--	0-40								
Permitted Housing Temperature	[°C]	--	90								
Weight	[kg]	*15	67								

*1) At nominal input speed, service life is 20,000 hours

*2) The maximum torque when starting or stopping operation

*3) The maximum torque allowed under a stress situation (Permitted 1,000 times during service life)

*4) The average input speed

*5) The maximum intermittent input speed

*6) Torque at no load applied to the input shaft at nominal input speed

*7) At this load and nominal input speed, service life will be 20,000 hours. (The radial load applied to the output side shaft center)

*8) At this load and nominal input speed, service life will be 20,000 hours. (The axial load applied to the output side bearing)

*9) The maximum radial load that the gearbox can accept

*10) The maximum axial load that the gearbox can accept

*11) The efficiency at the nominal output torque rating

*12) This does not include lost motion

*13) Contact NIDEC-SHIMPO for the testing conditions and environment

*14) IP65 (wash-down) is available as an option. Contact NIDEC-SHIMPO for more details

*15) The weight may vary slightly between models

EVB SERIES Right-angle Planetary

EVB 220 2-Stage Dimensions

Input bore size $\leq \phi 48 \text{ mm}$

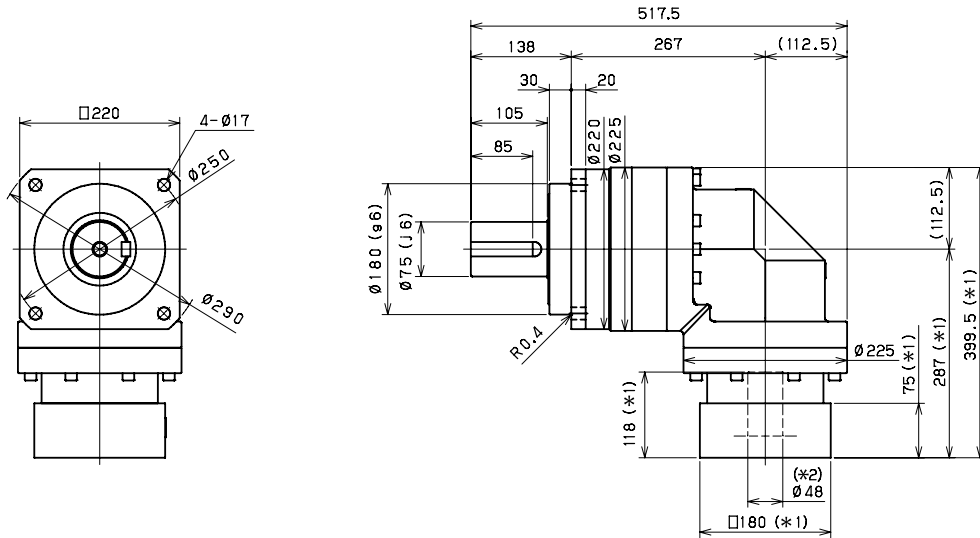

Input bore size $\leq \phi 65 \text{ mm}$

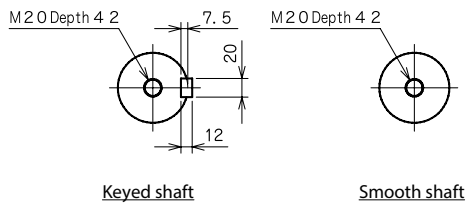
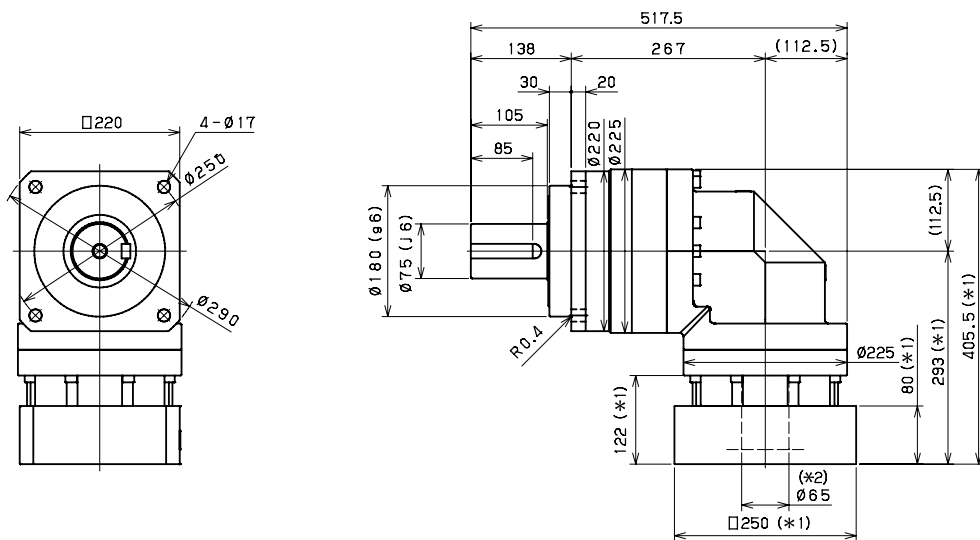

- *1) Length will vary depending on motor
- *2) Bushing will be inserted to adapt to motor shaft

EVB 220 3-Stage Dimensions

Input bore size $\leq \phi 38$ mm

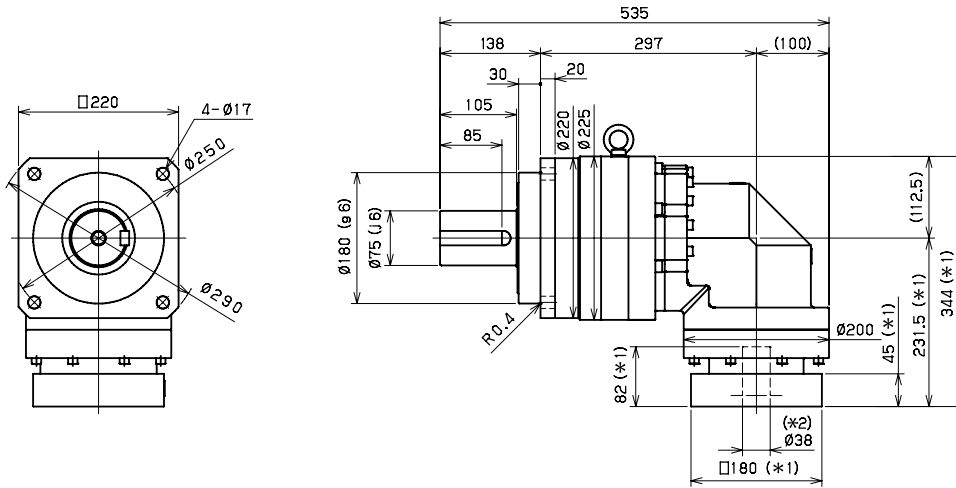

Input bore size $\leq \phi 48$ mm

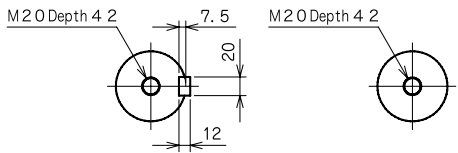
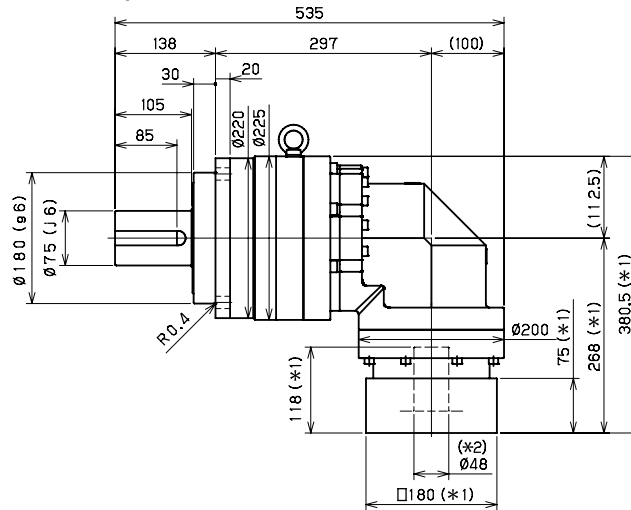

Keyed shaft

Smooth shaft

*1) Length will vary depending on motor

*2) Bushing will be inserted to adapt to motor shaft